

# ***Operating Instructions***

---

***Drill rig***

***BC-2***

*Index 001*

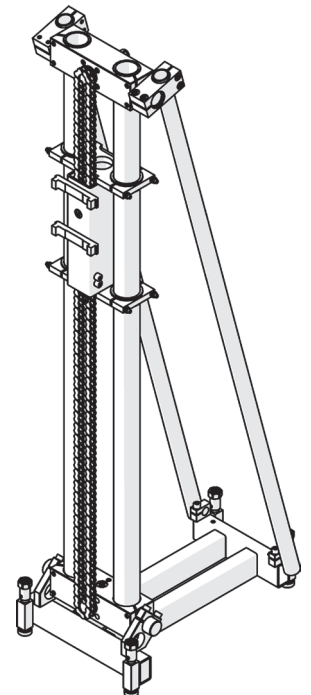

## **Congratulations!**

With a Hydrostress unit from **TYROLIT** you have chosen a tried and tested piece of equipment designed and built to the highest technical standards. Only genuine **TYROLIT** Hydrostress replacement parts can guarantee quality and interchangeability. If maintenance work is neglected or carried out inexpertly we will be unable to honour our warranty obligations. Any repair work must be carried out by trained personnel only.

Our after-sales service is available to help ensure that your **TYROLIT** Hydrostress units remain in perfect working order.

We hope that working with your TYROLIT unit will be a satisfying and fault-free experience.

### **TYROLIT Hydrostress**

Copyright © TYROLIT Hydrostress

TYROLIT Hydrostress AG  
Witzbergstrasse 18  
CH-8330 Pfäffikon  
Switzerland  
Tel: 0041 (1) 952 18 18  
Fax: 0041 (1) 952 18 00

# 1 Safety



These instructions are just one part of the documentation which is supplied together with the drill rig. These instructions go together with the "Core Drill Safety Manual / System Description" to form a complete set of documentation.



## **DANGER**

Failure to comply with the safety instructions in the "Core Drills Safety Manual / System Description" may result in serious injury or even death.

- ▶ Please ensure that the "Core Drills Safety Manual / System Description" has been read and understood in full.



## **DANGER**

**Death or serious injury can be caused by a sudden start-up of the machine.**

- ▶ Before switching on the system, ensure that no other person is present in the danger areas.
- ▶ Switch the system off before connecting or disconnecting cables.
- ▶ Switch the system off when you leave and secure it so that it cannot be switched back on again.

**Death or serious injury as a result of the drill bit continuing to run after an accident.**

- ▶ Ensure that the ON / OFF button can be reached quickly.

**Electric shock from live cables and connectors.**

- ▶ Switch the drill motor off before connecting or disconnecting cables.

**Risk of fire due to incorrect mains voltage.**

- ▶ Make sure that the mains voltage and mains frequency match the mains settings of the drill motor.

## 2 Description

### 2.1 Core drilling systems

- 2.1.1** The BC drill rig can be supplemented with suitable TYROLIT Hydrostress components to form an electrical or hydraulic core drilling system.

#### Electric core drilling system

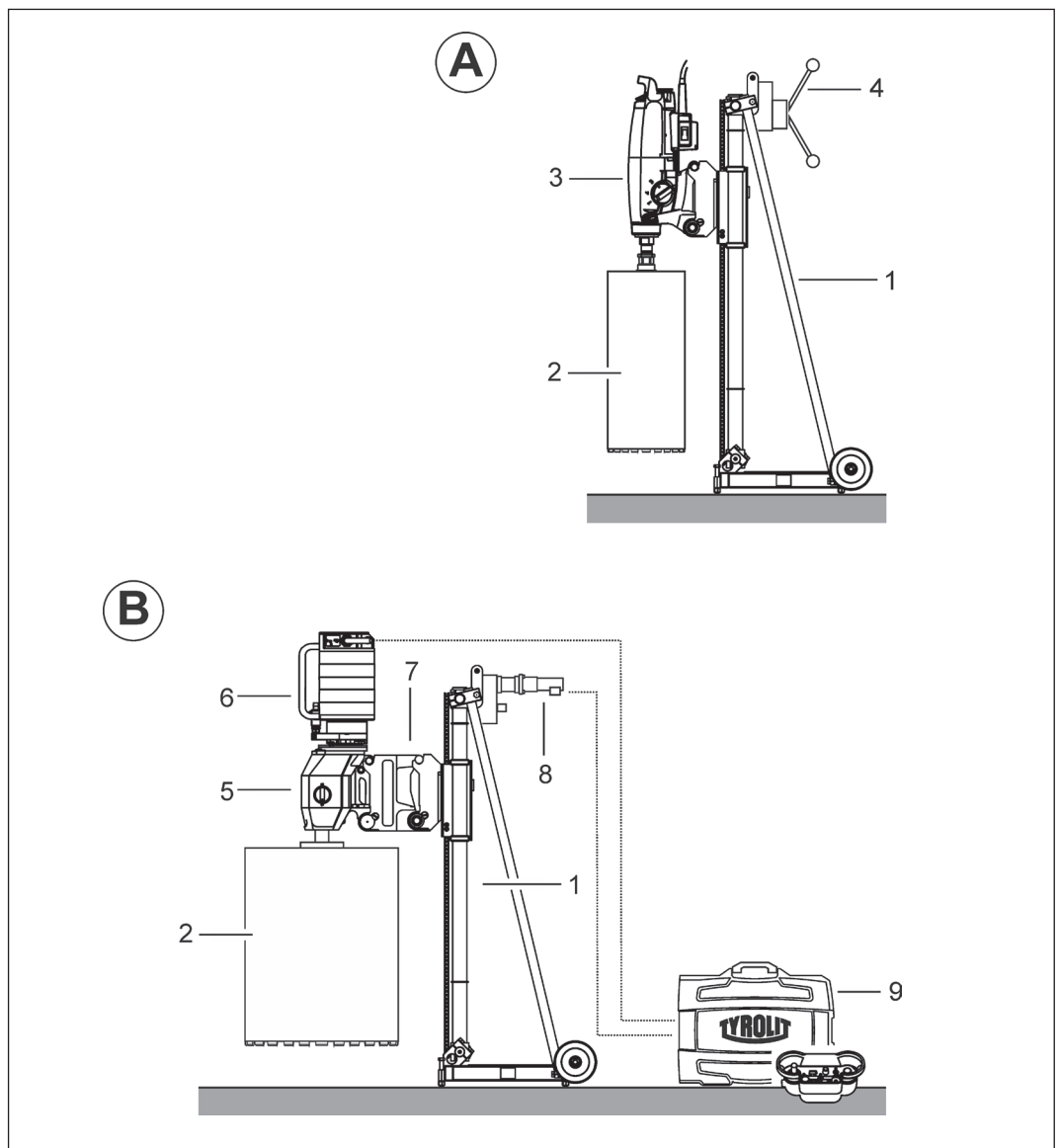

Electric core drilling system

- A Electric core drilling system with universal motor  
 B Electric core drilling system with WSE1217P drive technology for large hole drilling

- |                        |   |
|------------------------|---|
| 1 BC-2 drill rig       | 6 WSE1217P drive motor                    |
| 2 Drill bit            | 7 ModulDrill distance plates              |
| 3 Electric drill motor | 8 Feed motor                              |
| 4 Hand wheel           | 9 WSE1217P controller with remote control |
| 5 Drilling gearbox     |   |

## 2.1.2 Hydraulic core drilling system

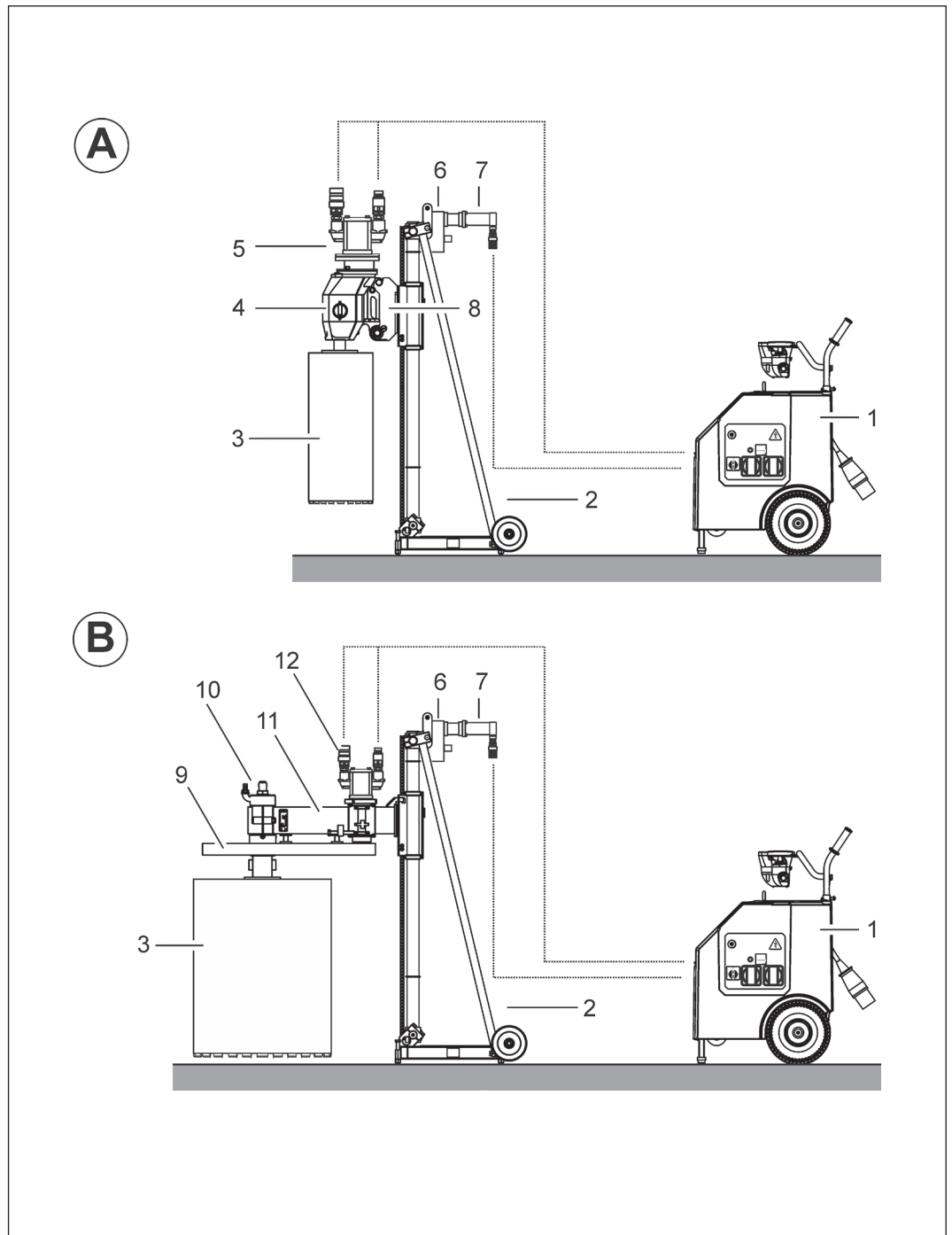

Hydraulic core drilling system

- A Hydraulic core drilling system with drilling gearbox
- B Hydraulic core drilling system with gearbox extension arm for large hole drilling

- |                               |                               |
|-------------------------------|-------------------------------|
| 1 Hydraulic drive unit        | 8 ModulDrill anchoring system |
| 2 BC-2 drill rig              | 9 Gearbox extension arm       |
| 3 Drill bit                   | 10 Drilling spindle           |
| 4 Drilling gearbox            | 11 Extension arm              |
| 5 Hydraulic drive motor       | 12 Hydraulic drive motor      |
| 6 2-stage feed gearbox        |                               |
| 7 Hydraulic-feed mounting kit |                               |

## 2.2 Main components

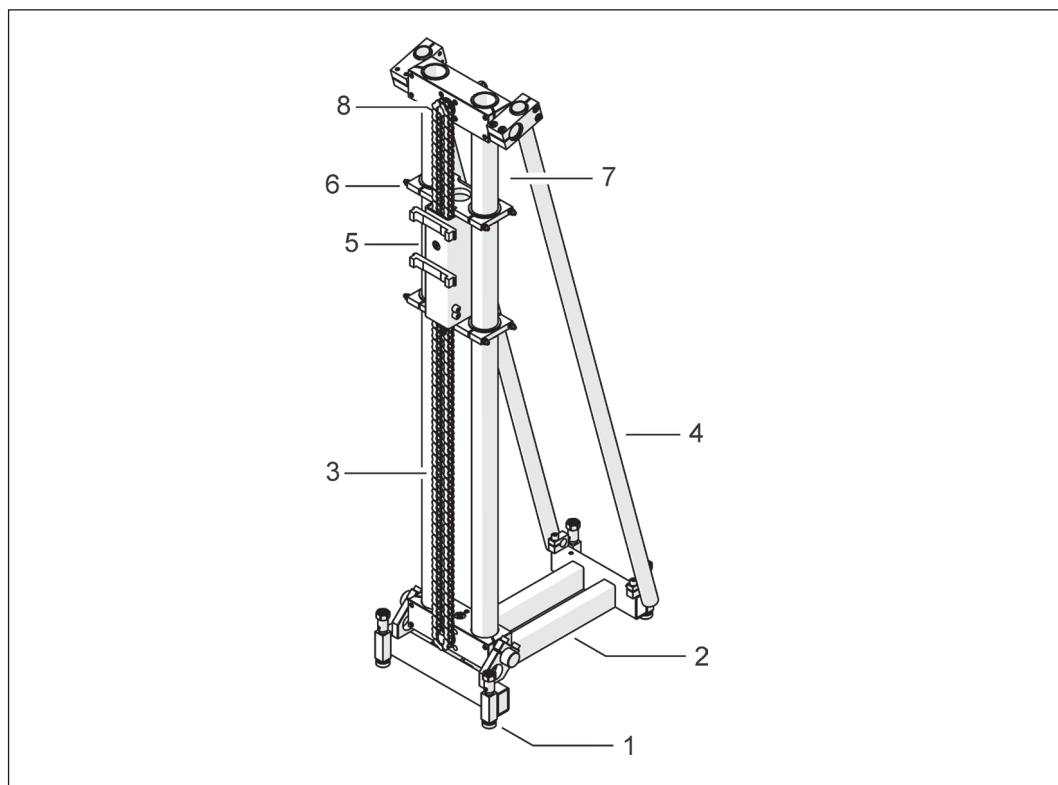

Main components

- |   |                 |   |                     |
|---|-----------------|---|---------------------|
| 1 | Adjustable foot | 6 | Support guide clamp |
| 2 | Chassis         | 7 | Guide tube          |
| 3 | Chain           | 8 | Drive shaft         |
| 4 | Support tube    |   |                     |
| 5 | Support         |   |                     |

### 3 Assembly

#### 3.1 Drill motor interface



The gear reduction arm, extensions and the ModulDrill mounting plate are connected to the support by means of bolted connections.

##### 3.2.1 Mounting the drill motor

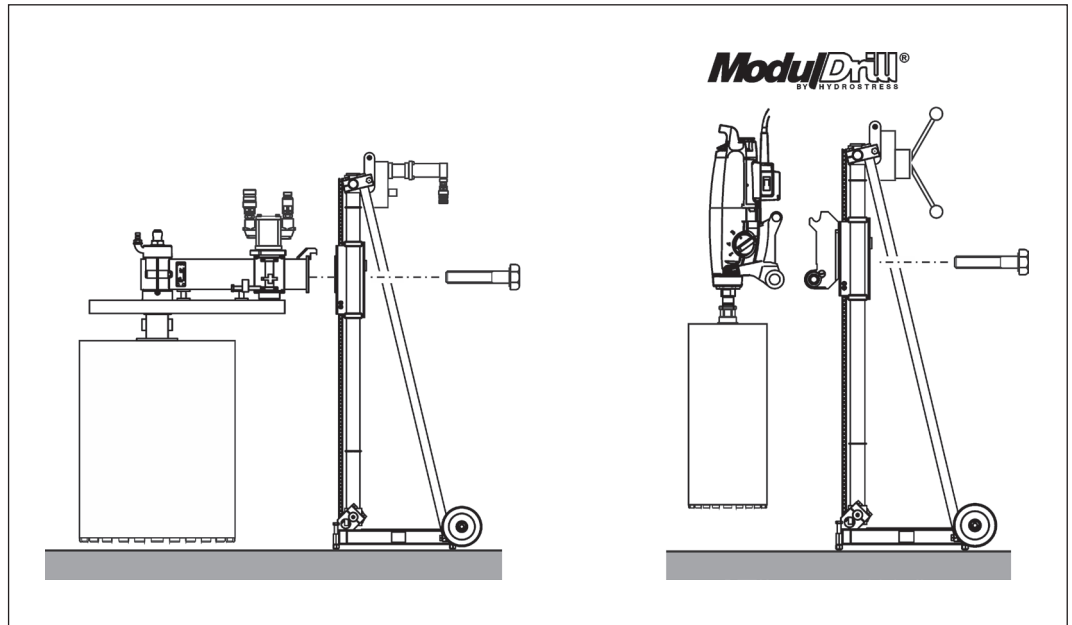

Mounting the drill motor

### 3.3 Interface to ground

#### 3.3.1 Dowel anchoring

The BC drill rig can be securely attached to the ground with dowel anchoring.

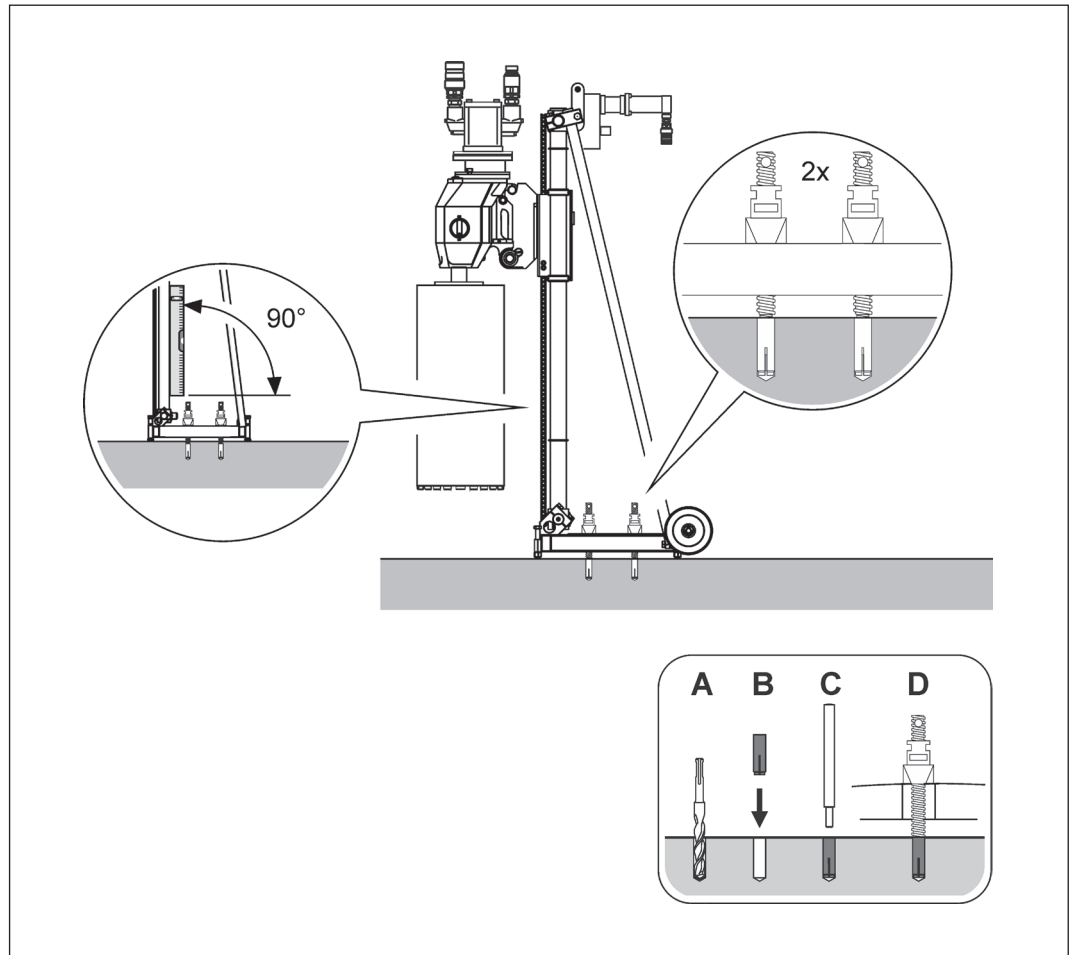

Dowel anchoring

Proceed as follows:

- ▶ Position the anchoring dowels specific to the ground surface as specified by the dowel manufacturer.
- ▶ Screw in the anchoring elements.
- ▶ Loosely secure the core drill rig.
- ▶ Set up the drill rig using a spirit level. The drill rig must be 90° to the ground for vertical bores.
- ▶ Attach the core drill rig securely to the ground using the two anchoring elements.
- ▶ Check the anchoring of the core drill rig.





To secure core drill rigs, anchoring elements appropriate for the ground must be used. When positioning the dowels, the installation instructions of the dowel manufacturer must be followed.

**Example:**

Dowel instruction leaflet

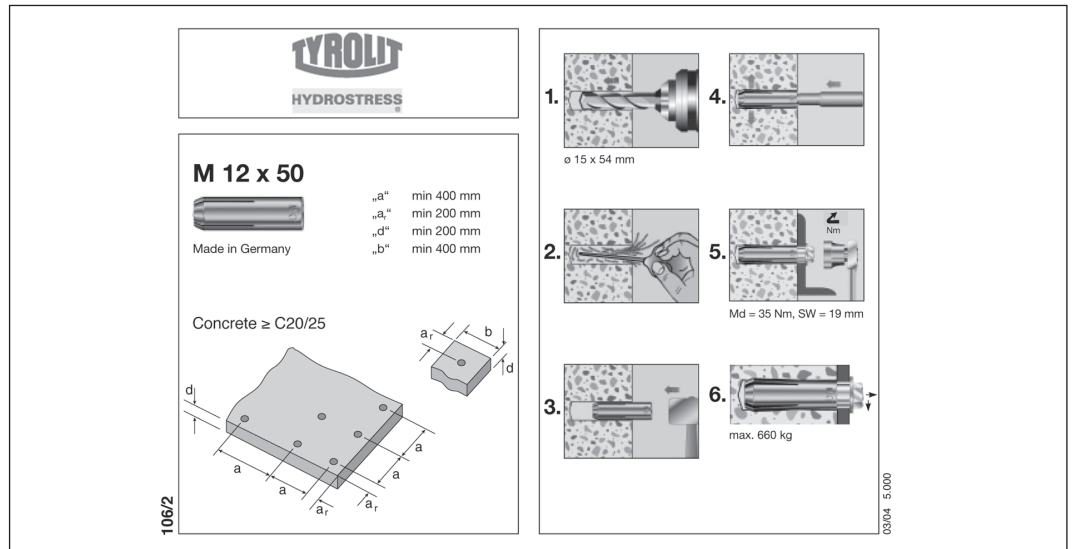

Anchoring instructions

**3.3.2 Dowel dimensions**

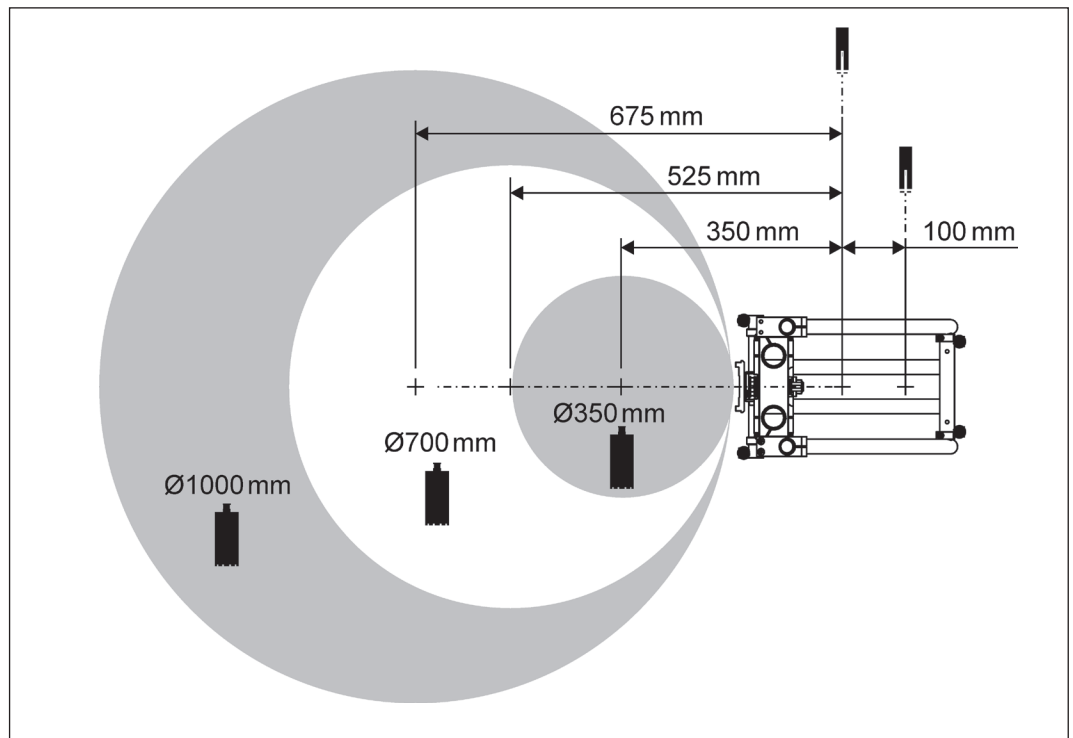

Dowel dimensions

## 4 Settings

### 4.1 Angled position

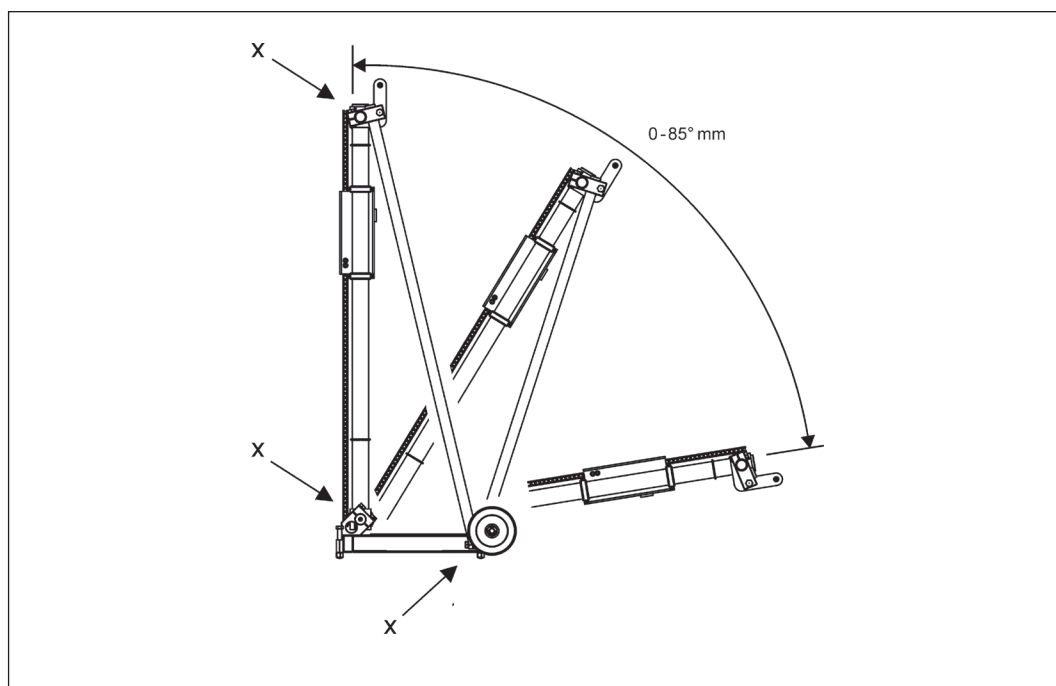

Angled position

#### Proceed as follows:

- ▶ Undo the bolts (x) of the guide carriers and the support rods.
- ▶ Tilt the guide rods to the angle required.
- ▶ Tighten the guide carrier and support rod bolts.

## 5 Servicing and maintenance

### 5.1 Maintenance table

Maintenance and servicing table							
		Before each use	After finishing work	Weekly	Annually	After faults	After damage
Drill rig	▶ Wash down with water		X			X	X
	▶ Lubricate threads of adjustable feet			X		X	X
	▶ Tighten loose screws and nuts	X					
	▶ Lubricate chain	X		X			
Support	▶ Tighten loose screws and nuts	X				X	X
	▶ Check sliding guide and adjust if necessary (see 5.4 Adjusting the drill rig guide)	X				X	
Service	▶ To be performed by TYROLIT Hydrostress AG or an authorised workshop.	First service after 100 operating hours Further services after every further 200 operating hours					

## 5.2 Checking the chain tension

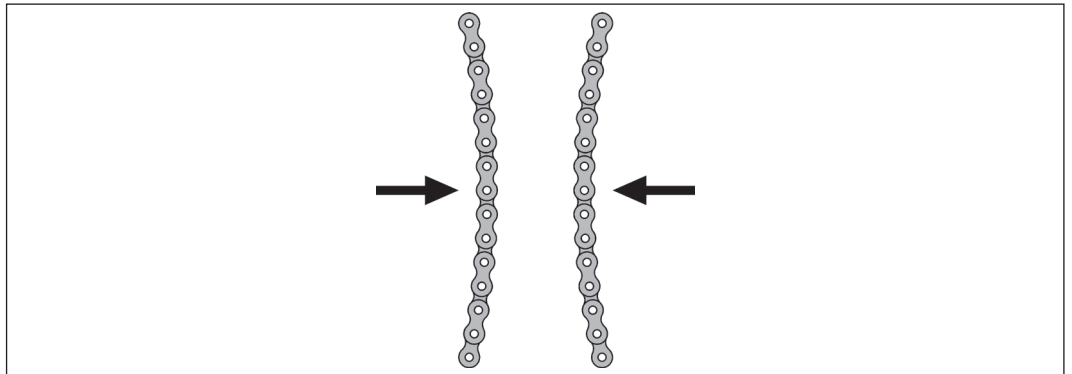

Checking the chain tension

### Proceed as follows:

- ▶ Press the chain together in the middle of the drill rig with thumb and index finger.



- ✓ The chain is tensioned correctly if it can be pressed together by hand.
  - The chain is too tight if it cannot be pressed together.
  - The chain is too loose if it can be pressed together without resistance.

## 5.3 Tightening the chain

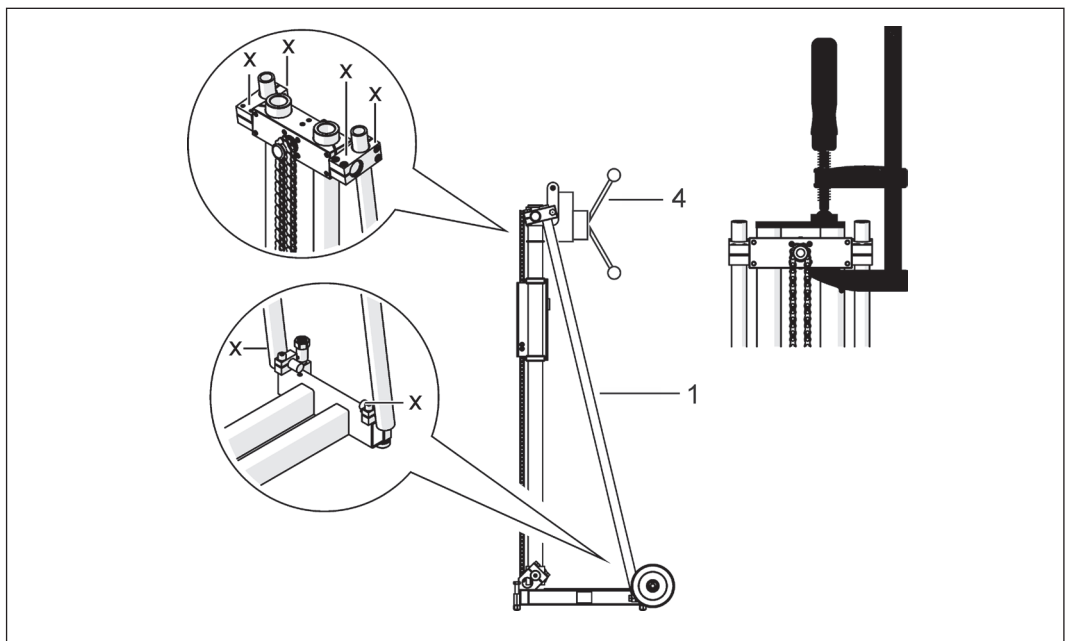

Tightening the chain

### Proceed as follows:

- ▶ Undo the bolts (x) of the guide carriers and the support rods.
- ▶ Tension the chain using a C-clamp and a steel plate until the correct tension has been reached.
- ▶ Tighten the guide carrier and support rod bolts.

## 5.4 Adjusting the drill rig guide

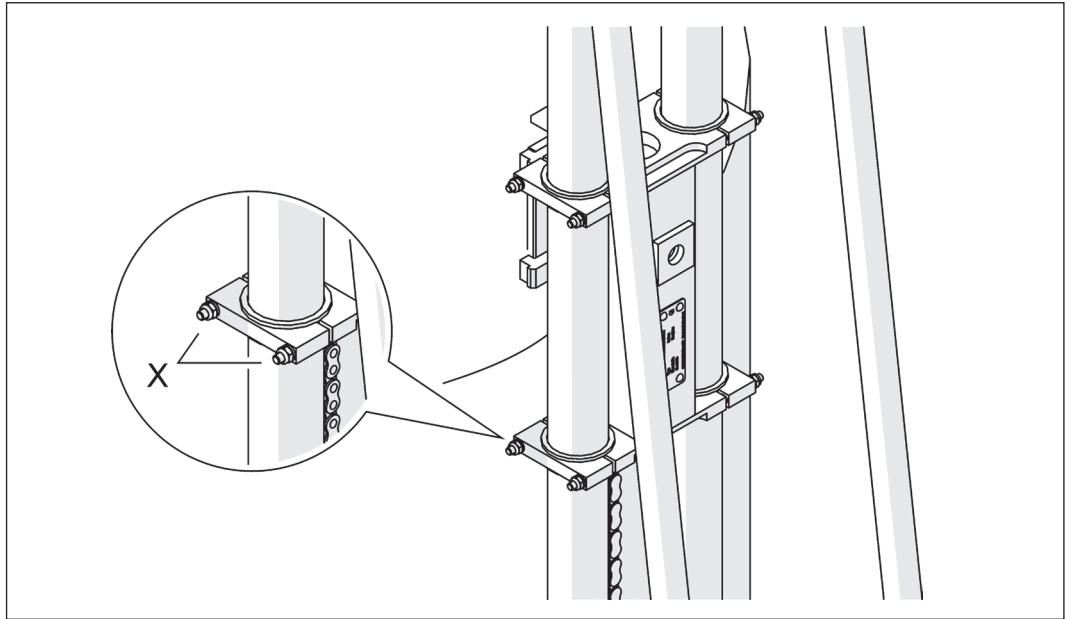

Adjusting the drill rig guide

### Proceed as follows:

- Tighten or loosen the four nuts (x) on each side of the drill rig.



The support must be free of play but still slide on the guide rods without needing much force.

## 5.5 Lubricating the chain

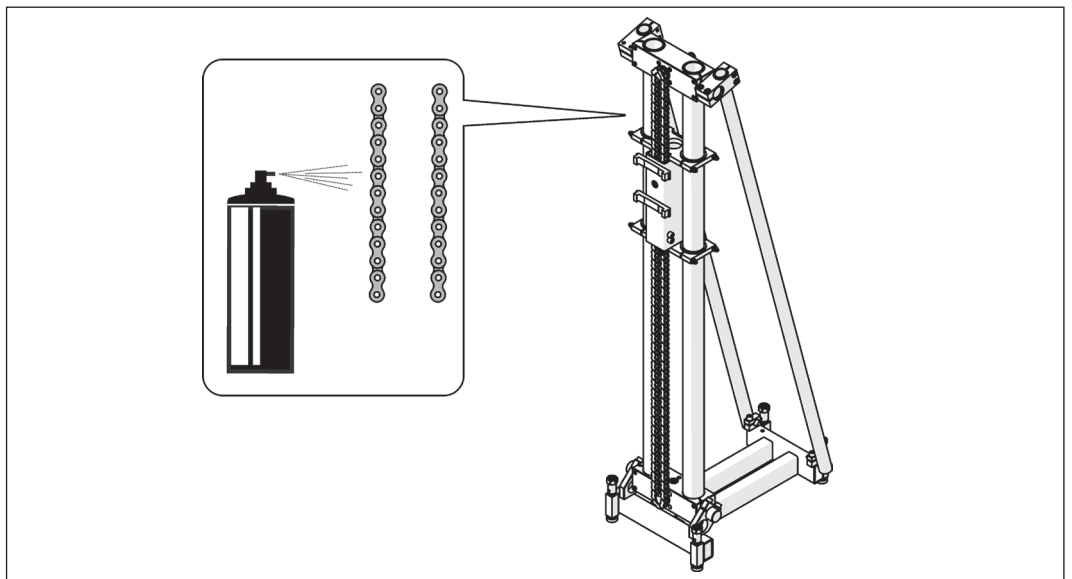

Lubricating the chain



Lubricate the chain with chain spray before starting work.

## 6 Faults

Faults		
Fault	Possible cause	Solution
Diamond drill bit jams	Diamond drill bit off centre due to inadequate anchoring of guide columns or drill rig foot	▶ Loosen and extract diamond drill bit. Break up drilling core and correct drill rig anchoring
	Diamond drill bit drifts due to excessive play in the sliding guides	▶ Loosen drill rig and readjust sliding guides
	Drill segments are worn (No free cutting)	▶ Replace drill bit
Major wear on the Drill bit tube	Poor guidance of the diamond drill bit in the drill hole	▶ Adjust sliding guides
	Defective drill motor bearings	▶ Replace drill motor ▶ Contact TYROLIT Hydrostress AG after-sales service.
Feed jams along the whole length of the guide	Locking device of the sliding guides is too tight	▶ Adjust sliding guide clamping
Difficulty in centring drill bit	Diamond drill bit off centre due to poor anchoring of the drill rig	▶ Correct drill rig anchoring
	Diamond drill bit drifts due to excessive play in the sliding guides	▶ Adjust sliding guides
	Poor concentricity of drill bit	▶ Replace drill bit ▶ Use TYROLIT diamond tool.
Difficult or impossible to turn the foot adjustment screws	Thread not lubricated	▶ Lubricate thread
	Feet bent	▶ Contact TYROLIT Hydrostress AG after-sales service
Difficult or impossible to incline the drill rig	Guide tube bent or damaged	▶ Contact TYROLIT Hydrostress AG after-sales service.

## 7 Technical data

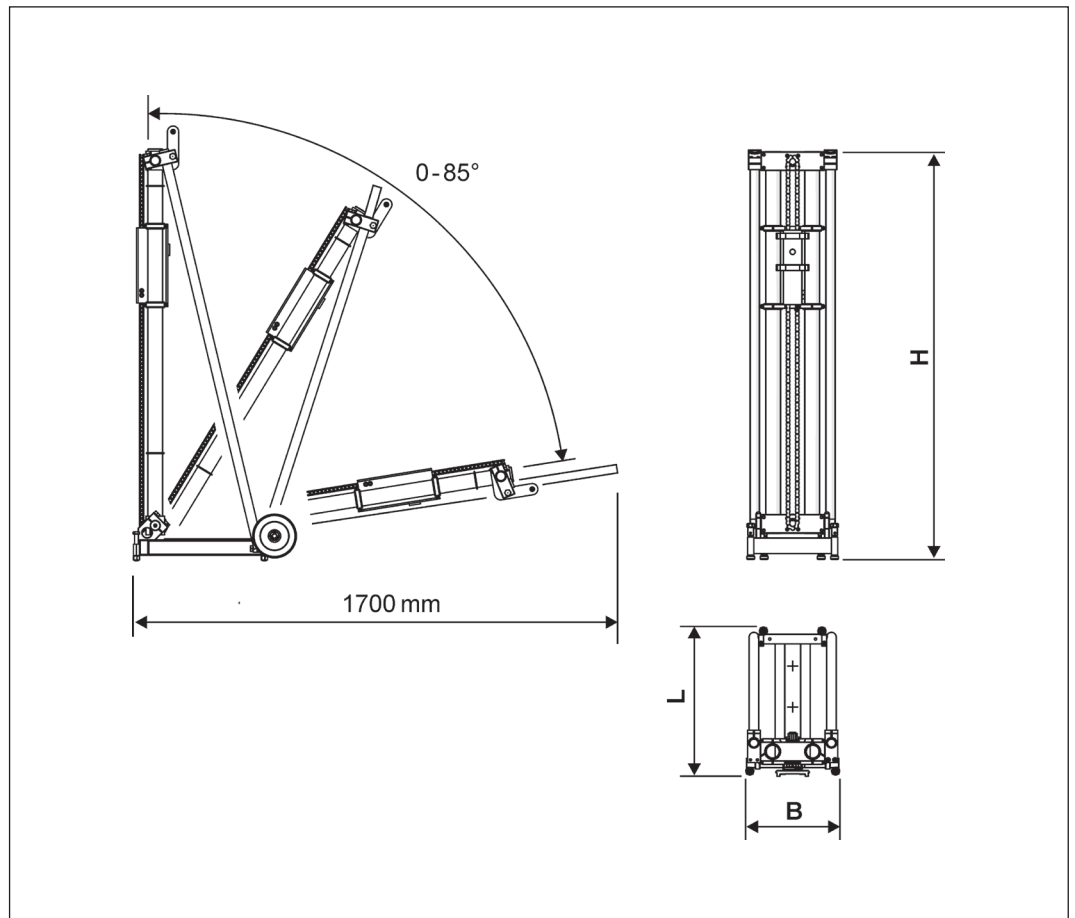

Dimensions

### 7.1 Dimensions

Dimensions	
BC-2	
Length L	465 mm
Width B	385 mm
Height H	1340 mm

### 7.2 Weight

Weights	
BC-2	
Weight (without hand crank)	30 kg

### 7.3 Drilling diameter ranges

#### 7.3.1 Hydraulic core drill system

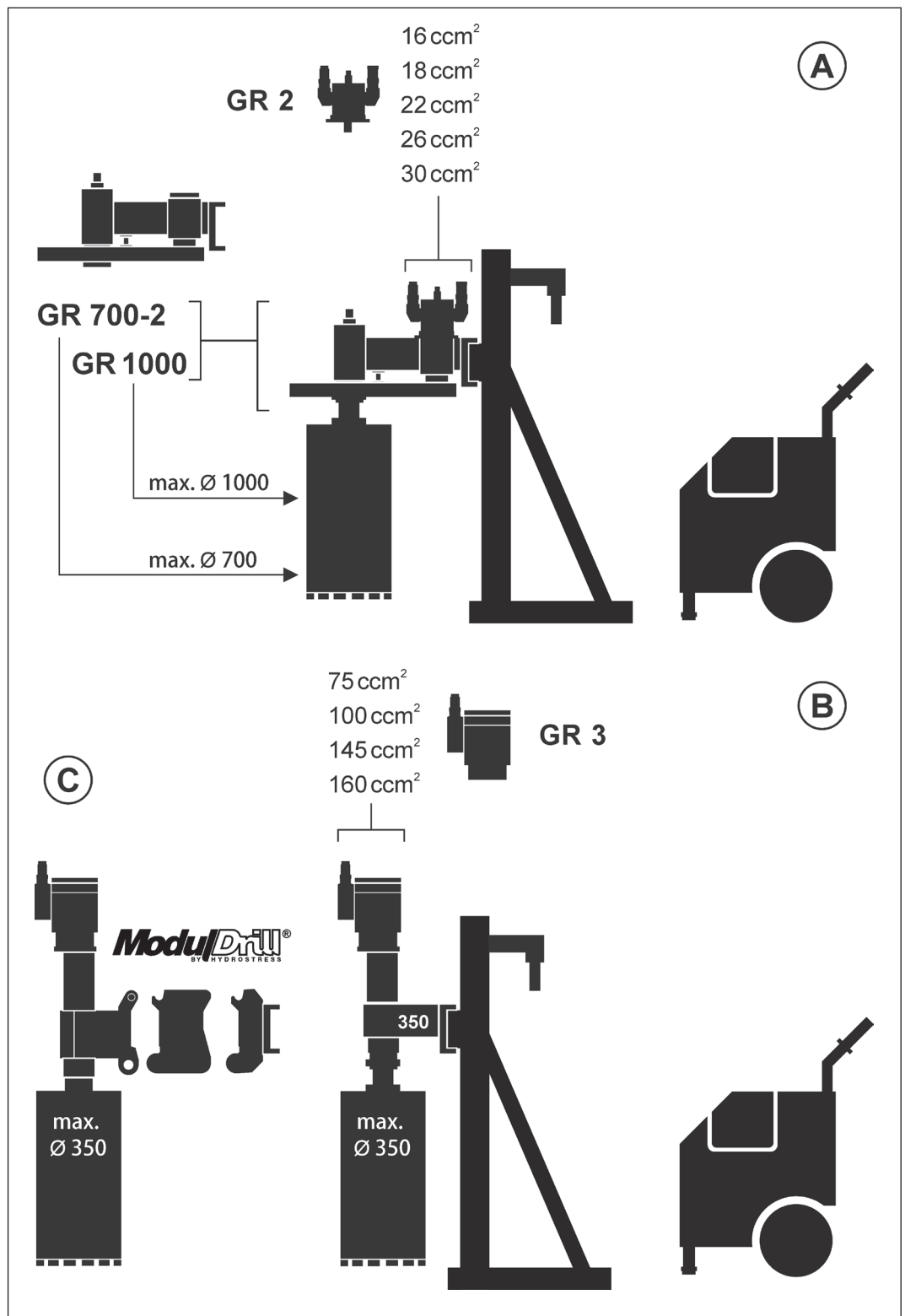

Drilling diameter of hydraulic core drilling system

- A Core drilling system with GR700/GR1000 gear reduction arm
- B Core drilling system with extensions and drilling spindle
- C Core drilling system with ModulDrill distance plates and drilling spindle support



### 7.3.2 Electric core drilling system

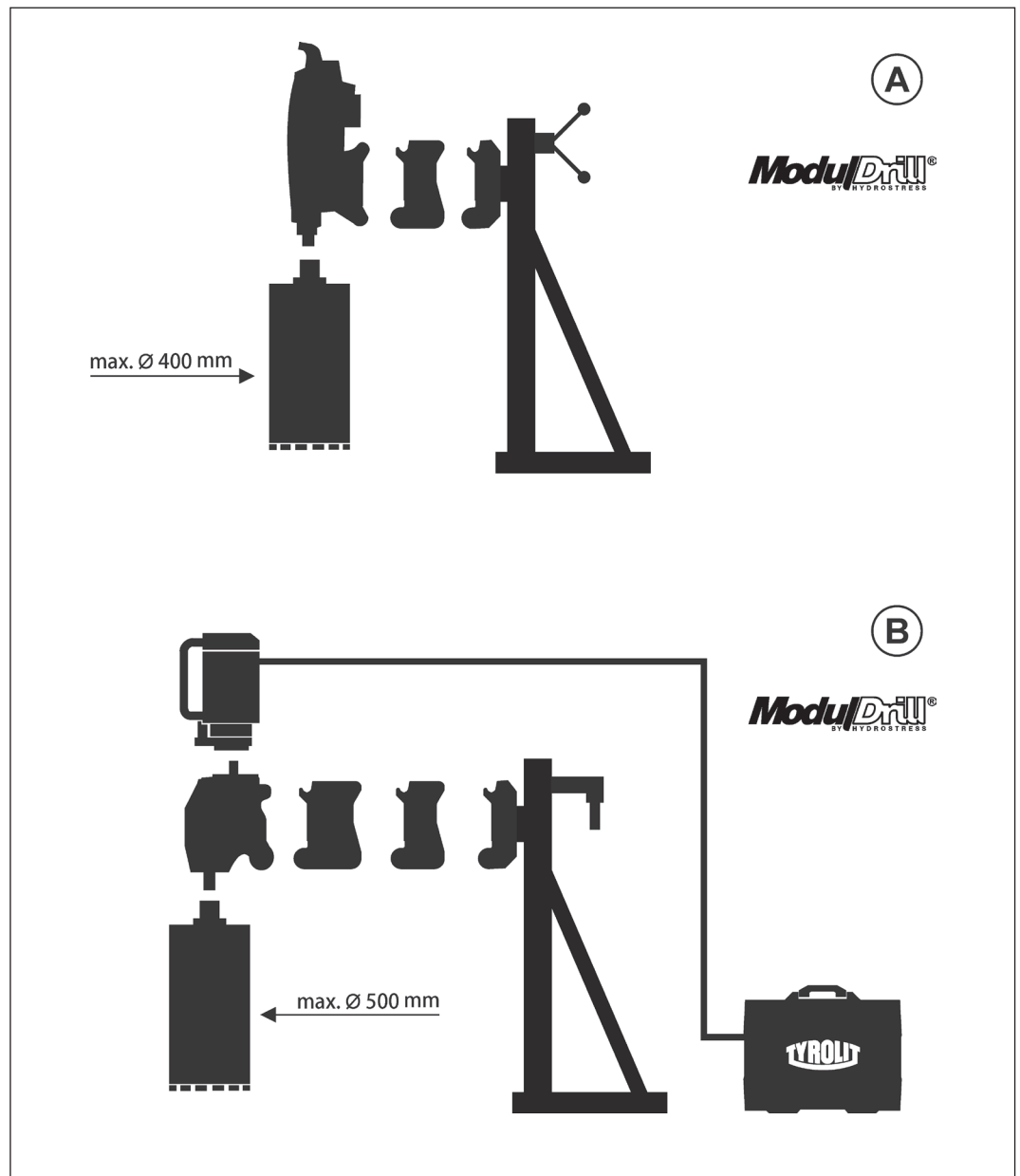

Drilling diameter of electric core drilling system

- A Core drilling system with ModuDrill distance plates and universal electric motor
- B Core drilling system with ModuDrill distance plates / drilling gearbox and P2 drive components with controller

## 7.4 Diamond tools

Drill bits	
BC	
Drill diameter range	Ø100 – Ø350 mm
Drill diameter range with gear reduction arm	Ø700 mm / Ø1,000 mm
Drill diameter range with extension	up to Ø1000 mm
Drill diameter range with ModulDrill distance plates	up to Ø1000 mm
Max. drill bit length	830 mm

## 7.5 Design

Design	
BC	
Foot	Steel dowel foot
Feed	By means of hand crank / electric feed motor / hydraulic feed motor
Two-speed feed gearbox	i = 2 and i = 9
Feed gearbox	1:3
Angular adjustment	0° – 90°
Adjustable feet	Micro
Drill motor mount	ModulDrill quick-release clamping system M12 screw plate

## 8 EC Declaration of Conformity

Description	Drill rig
Type designation	BC-2
Year of construction	2009

We declare under our sole responsibility that this product complies with the following directives and standards:

### Directive applied

Machinery Directives 2006/42/EC

### Standards applied

EN 12100:2010	Safety of machinery - General principles for design - Risk assessment and risk reduction
EN 12348:2010 + A1:2009	Core drilling machines on stands - Safety

Pfäffikon, 27/10/2016



Pascal Schmid  
Head of Development



